

Research & Development

[Introduction](#) | [Historical Background](#) | [Major Activities](#) | [Development of TARA Pump](#) | [Introduction of Mini Tara Pump](#) | [Download Research & Development Journal](#)

Introduction:

Ground water is predominant source of water supply system in Bangladesh. In rural areas, water supplies are generally provided by hand pump tube wells which tap water from underground. But in many places, water supplying with hand pump tube wells are facing severe problems due to various reasons. The major reasons are:

1. Lowering of Water Table.
2. Water Quality Problem.
3. Absence of Suitable Water Bearing Formation.
4. Arsenic Contamination Problem

DPHE is therefore, has been conducting Research and Development activities to improve existing technologies, develop cost effective alternatives and develop alternative technological option to provide water in the problematic areas.

Historical Background:

Considering the problem encountered in rural water supply a technical committee comprising experts from different organizations started their work on Research and Development activities before 1982. Because of water table depletion, hand pump other than #6 was very essential to be introduced in Bangladesh. After a series of discussions, workshop and field verification, TARA hand pump technology for low water table area has been developed in Bangladesh in the year of 1984.

Considering the importance and the magnitude of the R&D activities, it was felt necessary to establish a separate setup of manpower to be engaged in Research & Development activities. Accordingly, DPHE Research and Development Division was created in 1989 under GOB-Unicef project. The R&D committee headed by Superintending Engineer, DPHE Ground Water Circle comprising members from academic institutions, development partner has been playing advisory role on R&D activities since 1992.

In early nineties, detection of arsenic in ground water has caused a threat for ground water based water supply system in Bangladesh. On growing concern over arsenic contamination, a number of studies has been fielded to identify the causes of arsenic contamination, its magnitude and to find out the ways of arsenic mitigating technologies. Apart from this, a number of alternate water options are being explored in the field to evaluate the performance of the options in terms of technical and social aspect.

Major Activities:

Recent Research and Development Activities in DPHE : The Department of Public Health Engineering (DPHE) has initiated a number of program/activities to cope the sector challenges and impact of climate changes through it's Research and Development Division. Some of the initiatives are mentioned below;

1. Piloting Improved Pond Sand Filter (PSF) in Coastal areas utilizing solar energy supported pumping system:

In cooperation with the Oxfam-GB Bangladesh, DPHE R&D Division had taken an initiative to apply the improved design of PSF in the coastal areas during the year 2009 and 2012. Under this improved design solar power has been utilized to pump water from the pond to the filter bed of PSF. A sensor has also been provided in the treated water chamber so that the raw water pumping remains automatic during the day. Generally this is been done using a hand pump, where the users are supposed to pump water on the filter bed before taking water from the PSF. On the other hand, by providing a lighting system, the users especially the women were facilitated to collect water from the PSF during night. 20 of such system have been installed in Jessore (Manirampur), Satkhira (Ashasuni) and Khulna (Koyra) district. A system generally costs BDT 3.00 lakhs. The following photographs demonstrate the piloting to some extent;



Improved Solar PSF



Improved Solar PSF



Solar Centrifugal Pump

2. Action Research on Managed Aquifer Recharge (MAR) in Coastal Areas of Bangladesh:

The action research has been initiated during September 2009 and continued upto December 2013. Afterward a scaling program followed it that continued upto June 2015. It is been a collaborative action research, where the Dept of Geology, Dhaka University and AcaciaWater from the Netherlands was providing technical consultancies, UNICEF had been providing the financial support and DPHE was administering. Some technically selected areas in south western coastal belt, where sweet water aquifer is scarce or unavailable were covered in this study. 20 Managed Aquifer Recharge (MAR) Systems were constructed in 09 Upazilas in Satkhira, Khulna and Bagerhat District during the 1st phase of the action research and additional 80 systems were constructed under the scaling up program. Through these systems, during monsoon, rain water is injected in the aquifer system using gravity flow/pumping. The water retained in the aquifer get diluted with saline water and can be used in dry season as fresh source of water. A typical system generally costs around BDT 6.5 lakh. These systems are now under monitoring phase. It is expected that the monitoring shall continue upto December 2016. After the systematic monitoring and interpretation using computer based modeling/simulation, research question will be answered with facts & figures including technical feasibility, efficiency, cost effectiveness and social acceptance of MAR systems. Based on the evaluation, an expansion program can be undertaken with UNICEF/Dutch support in other part of the Coastal Belt or the Country.



A typical MAR System

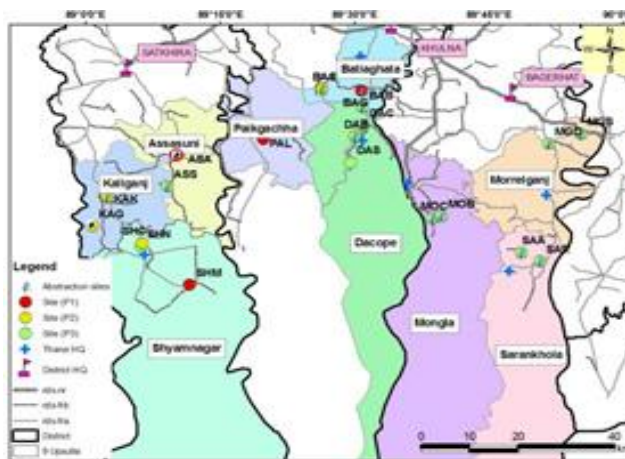

MAR System Location Map

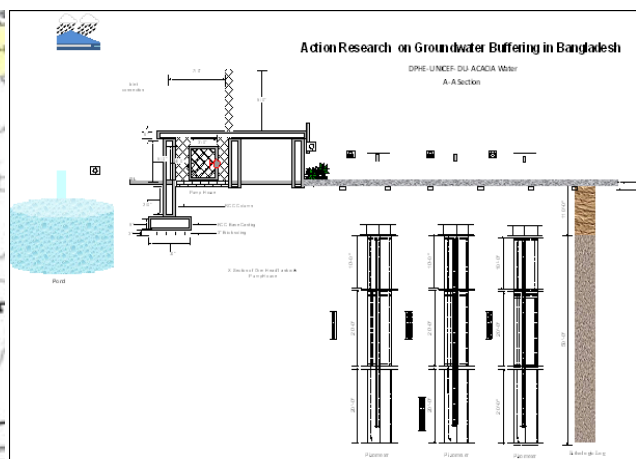

MAR System Design

3. Joint Action Research on Salt Water Intrusion in Groundwater; in the Coastal Areas of Bangladesh:

This joint action research has been initiated with the financial support from the Government of Bangladesh, DANIDA, HYSAWA, IWM and ITN-BUET during October 2010 and continued upto June 2015. Institute of Water Modelling (IWM) is a contributory consultant of this initiative. Part of Khulna and Satkhira district (10 Upazila, Apporx 1534 Sq. Km areas) is covered in this research. Both ground and surface water were monitored for its quality especially for salinity and quantity through the study. Baseline, midline and end line survey was conducted to observe the rate of saline water intrusion in the study area. 45 observation wells including 36 line well were installed in different areas which were under continuous monitoring on a weekly, monthly and

quarterly basis. Water samples were tested in DPHE Khulna lab periodically. Line well is installed along/across the river of Kazibacha, Gangrill and Kapadak. 8 Automatic level loggers are fitted in line wells for continuous water level monitoring. Beside this, 300 public/private wells were surveyed under baseline, midline and end line survey. Hoever, electric logging, pumping test were also been carried out to examine the aquifer properties/potentials. After the full length data collection, computer based simulation/ modeling was used to interpret the data and thereby rate of salt water intrusion, it's extent and magnitude were predicted. From the observations it can be mentioned that there are very insignificant impact of surface saline water with the deep groundwater but shallow groundwater is dynamically linked with the surface water. Due to saline in the shallow groundwater, by the year of 2050, within the study area 3.44% of fresh water pocket areas might be converted into saline water areas.



Measurement of Water Quality

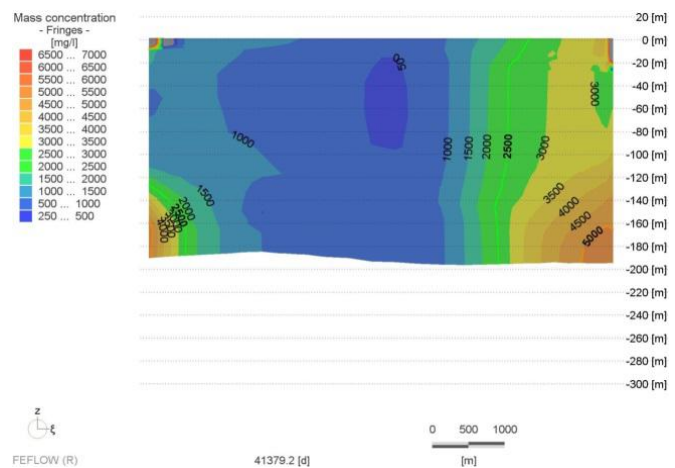

Horizontal Saline Aquifer Distribution

4. Piloting manually operated hydraulic and hybrid pumps in the low water table areas of Naogaon District:

With financial support for UNICEF in the year 2014, DPHE R&D division initiated a piloting that involves installation of manually operated hydraulic transmission and hybrid (tara) pump in low water table areas of Naogaon. The objective of the piloting was to observe the technical effectiveness of high lifting manual pumps in rural areas where number 06 hand pumps do not work during dry season. Under this piloting, 20 Novea hydraulic pump (imported from France) of 30m lifting capacity and 10 locally made hybrid tara pumps (20m lifting capacity) were installed in Sapahar, Porsha and Patnitala Upazila. Both the foot and hand operated pumps were tried under this piloting. These pumps are now under evaluation process. After the interpretation of the evaluation report, it is expected that the technical viability together with the social acceptance of the pumps shall be assessed. Following photographs represent the pumps in the field and its technical diagram for quick reference.



Hand Operated Hydraulic Pump

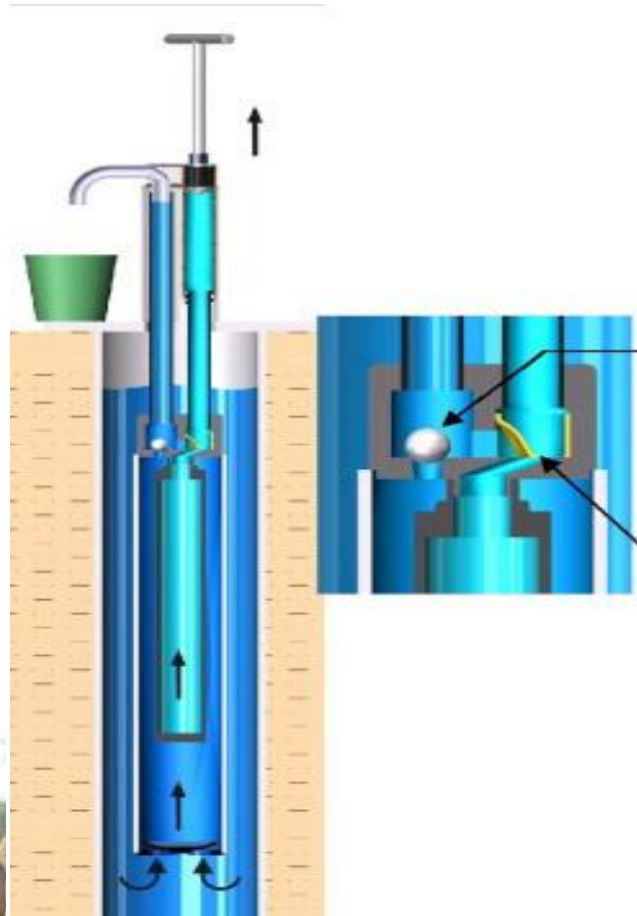

Hand Operated Hydraulic Pump

Implication of Declining Water Table: Since 1986, DPHE has been monitoring the fluctuations of groundwater table using a measuring network having one tubewell in each union of the country. Measurements are taken once annually during peak dry season. The data indicates the area where the water table has fallen beyond the suction limit has increased from 12% in 1986 to 20% in 1990. As a result a large number of tubewells fitted with no 6 suction pump become non-functioning during dry season. During 1992-95 an in depth study had been carried out to predict the area of the country where the water table would be beyond the suction limit in the year 2010.

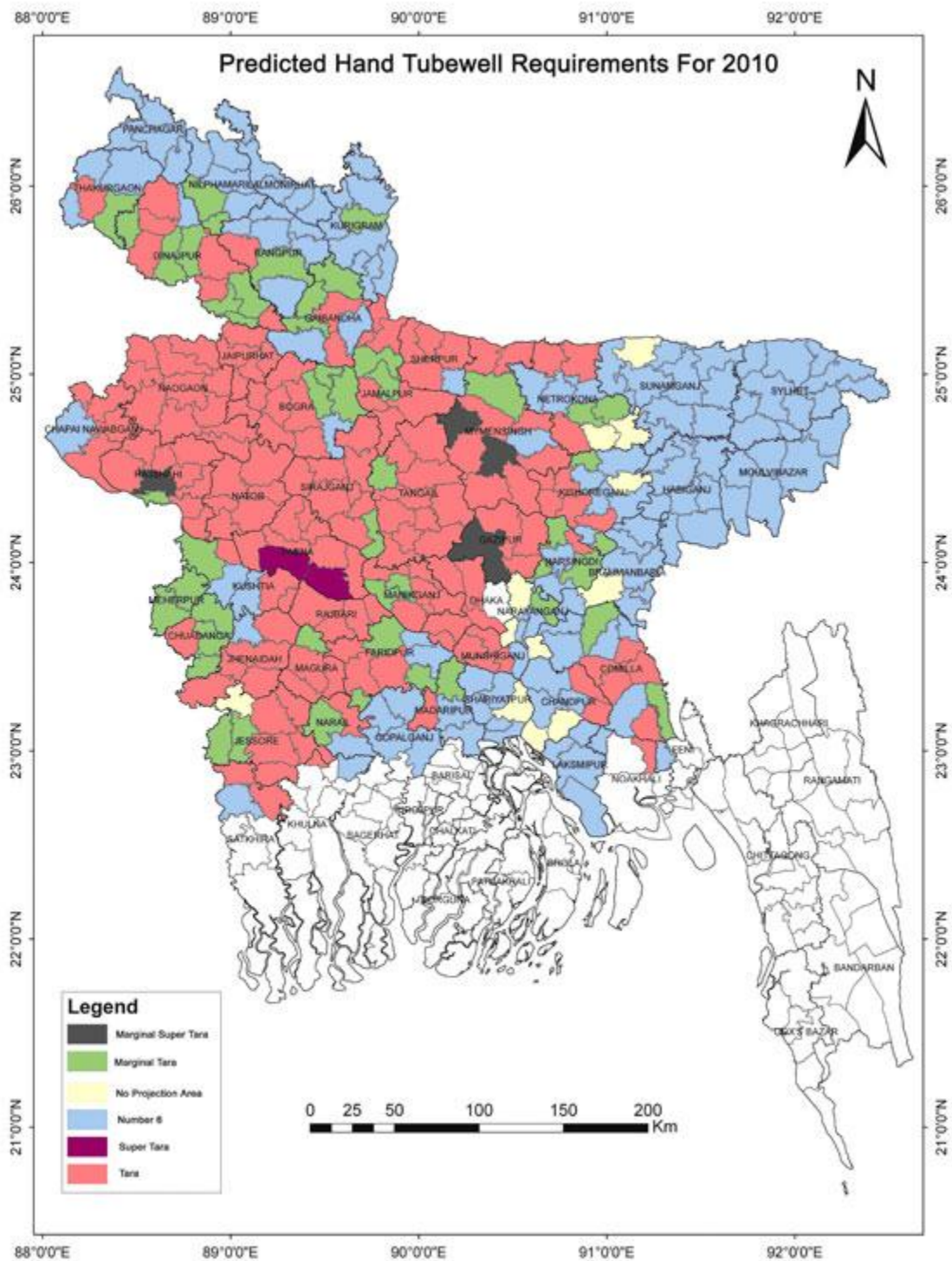

Findings on water table monitoring shows that water table has fallen beyond suction limit about 27% in 2004. However, declination of water table should be analyzed for deep and shallow aquifer has been undertaken.

Development of TARA Pump:

Due to declination of water table, a large number of no 6 suction pump started to be inoperative particularly in dry season in different parts of the country. To cope up the problem, Tara pump has been developed based on principle of displacement pump. The pump is submerged in water connected with handle through piston rod. It can yield water within 15meter water table.

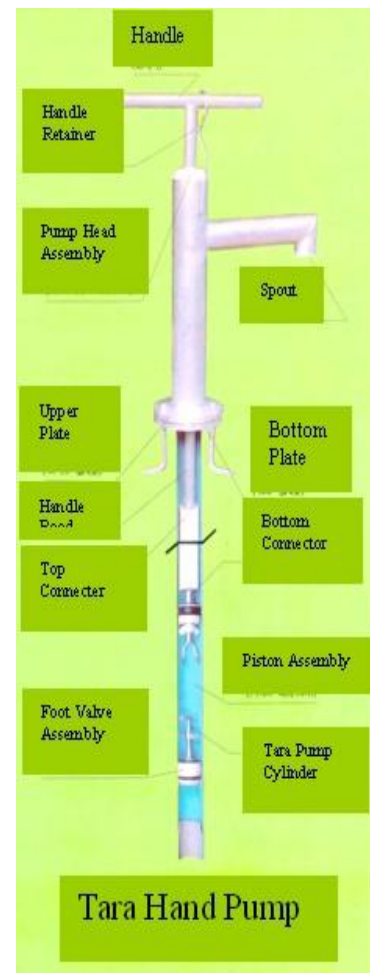

Introduction of MINI TARA & Extended piston in 1.5 inch dia shallow well:

It was estimated that a some of 360,000 public tubewells would be inoperative in near future due to gradual declination of water table. To replace these wells by 2-inch dia TARA tubewells was considered to be expensive. In that context, with the support of Unicef, R&D Division had initiated in 1991 to come up modified TARA pump that can fit in the existing diameter of No 6 pump shallow tubewell with minimum modification. The conversions were named as MINI TARA. Initially a test of MINI TARA was performed and 23 nos of such wells were installed. But due to some fault in the design the work was discontinued. However, some development had been made on 10 nos of such wells and tested in the field. 100 Mini Tara were installed in Joydevpur of Gazipur District. Intensive monitoring related to installation technique, performance, maintenance and user's reaction were done.

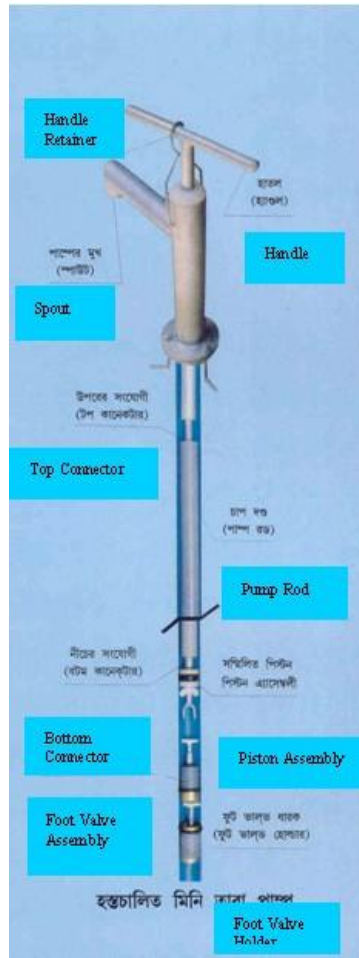

Mini Tara Hand Pump

In an evaluation over the performance of Mini Tara, it was found that these pump operated well up to 2-3 years. But some difficulties was faced during repairing pump assemble. In that case, back up support is needed to make it sustainable.

Development of TARA-II and TARA DEV Hand Pump:

TARA hand pumps were installed at 15m depths in low water table areas. In some parts of North Bengal the water table was declining beyond the capacity of Tara pump. To cope up the situation TARA II had been developed and conducted field-test in the year of 1988 to lift water from 30 meters depth. An evaluation by the R&D Committee in early 1992 was indicated that Tara-II fitted with No 6 pump head could be used as an interim solution. Accordingly 150 nos TARA-II tubewells had been installed in later part of 1992-1993 fiscal year. However, further study on these pumps fitted with No 6 head had been carried out to improve the vertical movement of the pump rod. Tara technology having lever action pump is termed as TARA Dev.

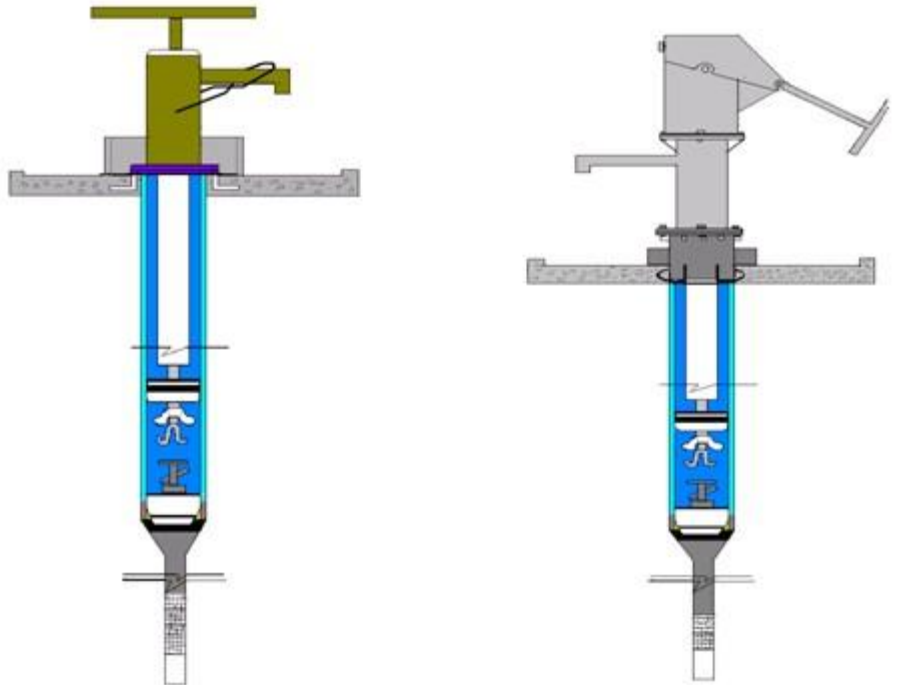

Direct action tara and Tara Dev

Concersion of DSP into TARA: The conventional deep-set pumps were becoming obsolete due to difficulties & expensive maintenance. These wells could easily be converted into TARA, provided the upper well casing remains within water level. 10 nos of such conversion had been made in Ghatail thana of Tangail district. It was proposed to install further 40 such wells to observe the performance; maintenance and construction defect if any to standardize the design.

Water Quality Problem:

Coastal Belt Mapping Updating: In coastal belt areas the major problem encountered in tubewell was salinity of excess concentration. Besides this, in some places no suitable aquifer was available. In 1990-91 a detailed map of the coastal belt was prepared showing different problem areas on it. After that, extensive work to find out suitable water bearing layer was done. By this time some areas were found successful, some areas found unsuccessful for normal hand pump well, where alternate technologies were being applied and some new areas with different problem were identified. All these changes were incorporated in the maps and the coastal belt mapping were updated. The exercise was started in 1993 by conducting 4 workshops in this regard. The activities continued up to 1995 and the maps were again updated.

Danida Supported R & D activities under DPHE- R & D Division

Pond Sand Filters (PSF):

R & D Model PSF:

From the assessment of ITN model PSF it has been revealed that it costly to accommodate by poor household, construction and O & M seems a bit difficult by local private sector and users. Then R & D division has taken initiative to develop a new design. Accordingly the designed has been made and piloted. The design capacity is for about 40 families ie about for 200 users. The estimated cost is about Tk 30000/. The user contribution is 20 % of the estimated cost. It has been monitored for about 7 months for technical, socioeconomic, management and O & M aspects. The findings are satisfactory to be replicated.



Rain water Harvesting System:

R & D division has designed and piloted community based Rain Water Harvesting System (RWHS) to serve 3 to 5 families ie about 25 to 30 users for drinking and cooking purpose. The storage tank volume is 2500litre. The construction cost is about Tk 11000/. The user contribution in construction is 20 % of the estimated cost. The models designed to ensure 7 months water security. It has been monitored for about 7 months for technical, socioeconomic, management and O & M aspects. The findings are satisfactory to be replicated.

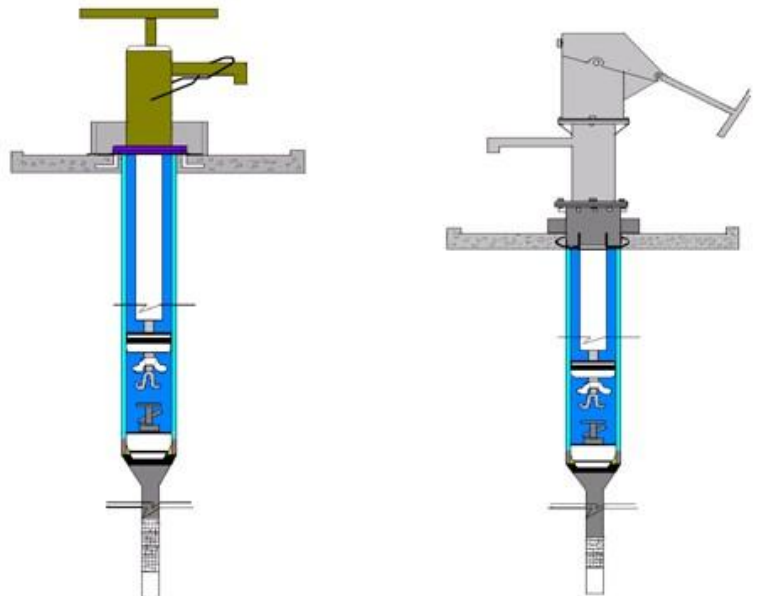

Direct action tara and Tara Dev

Piloting on Water Source with Raised Platform:

After 2004 flood, it was planned to construct water source with raised platform in flood shelter or strategic location as emergency preparedness so that the flood distressed people can get water form these sources during flood. In these context water source with raised platform was designed and piloting of 20 no such technologies was carried out in Narsingdi, Lakhmipur, Sylhet and Moulvibazar (5 nos at each district).



**Narayanpasa Govt. Primary School,
Moulvibazar**



Jalalabad UP office, Sylhet

In evaluation it was found that water point with raised platform installed in flood shelter (mostly school or college where people take refuge during flood) or strategic location would be used by the people in normal time and be useful during flood period. Following the findings of piloting, the said technologies were incorporated in the UNICEF assisted Post Flood Rehabilitation project. Under this project about 3500 nos such technologies were installed. After 2007 flood, carried out by CEGIS revealed that these options were very effective during flood.

Pond Sand Filters (PSF):

a. Iron Removal Unit



As a part of the DPHE-UNICEF R & D activities, 10 nos Iron Removal Units have been constructed with different models including using VS ring. Water quality monitoring including its performance evaluation as regard to O&M and acceptability by the community will be start at last part of February 2008. removal of manganese also be include in water quality monitoring programme.

b. Mark-3 and Afridev Technology

It was reported that some part of the country (particularly Rajshahi zone), facing acute lowering of water table exceeding 100 ft. In these areas Tara-dev is not suitable. So Mark-3 and Afridev pump capable of abstracting water having water table around 150 ft. has been taken for piloting under DPHE-UNICEF R&D activities. 5 such tubewells (1 in Tongi, 2 in Chapai Nawabganj and 2 in Rajshahi) have already been installed. These technologies will be monitored, reviewed and to be modified for make it more suitable in terms of performance and cost of the technology as well.

c. Safe Water System (SWS): Household Chlorination of Dug well

Piloting on point of use water treatment technologies has been undertaken by DPHE-WHO-UNICEF initiatives. Under these piloting household chlorination is being done in the dugwell of Homna upazilas. EPRC and TWSDA have been engaged as a partner agency. Baseline survey has been completed. Other works like distribution of disinfectant, motivation of the community, testing of water quality is going on.

d. Drilling deep tubewell in gravel problem area



Figure : Three pumps are using as a circuit

In some region in the country including arsenic affected areas, deep drilling is very difficult due to existence of gravel layer. As a part of DPHE-JICA initiatives, piloting on improvement of water jet method was undertaken to penetrate the gravel layer. Using the said method five deep test drilling have successfully installed in gravel problem areas like Harirumpur of Manikganj and Damurhuda of Chuadanga, Ckougacha of Jessore, Bera of Pabna. In Bera and Chowgach, arsenic free aquifer could not be found. In Manikganj, more deep drilling will be done using the said method for confirming the deep tubewell as a suitable option in Manikganj areas. The final report is under preparation for printing.

d. Effectiveness of sealing on deep tubewell



According to the protocol of deep tubewell mentioned in Arsenic policy, sealing is to be done to prevent the leaching of arsenic in deep aquifer through drilling hole. Accordingly clay sealing is being done in deep tubewell. But the procedure of clay sealing raised some confusion regarding its effectiveness. In this context as a part of the DPHE-JICA R&D activities, initiatives has been undertaken to findout the best possible procedure of clay sealing and to examine its effectiveness. Two tubewells of 1.5" diameter were installed at first for experimenting gravel shrouding and clay sealing with clay balls(Clay: Bentonite = 1:1). Three tubewells of 3" diameter were installed and among those one was sealed with cement, one was sealed with clay ball and the rest one without any sealing. Tracer element test was carried out to verify leaking of sealed and without sealing wells. Water samples are now in lab for chemical analysis. Three tubewells of 1.5" diameter were also installed in same methods of which one was sealed with cement, one was with clay ball and the rest one ithout any sealing. Tracer element test for these tubewell will be done very soon. All the tube wells are installed in Kadamtal , Benapole upazila.